

Design Details

5

System Design

Walling Installation

D-01 - General Walling p⁴⁸

D-02 - Plan View of SK1N System p⁴⁹

D-03A - Section View of L Shape on Timber Battens or SK1N Top Hats p⁵⁰

D-03B - Section View of U Shape on Timber Battens or SK1N Top Hats p⁵¹

D-04 - Cavity Options p⁵²

D-05 - Internal Corner p⁵⁴

D-06 - External Corner Options p⁵⁴

D-07 - Cutting Guide for External Corner Tiles p⁵⁵

D-08A - Window Sill Detail p⁵⁶

D-08B - Window Head Detail p⁵⁷

D-09 - Eave Junction p⁵⁸

D-10 - Roof Junction p⁵⁸

Roofing Installation

D-11 - SK1N Roof with Ply Underlay Side View p⁵⁹

D-12 - SK1N Roof with Ply Underlay Front View p⁶⁰

D-13 - SK1N Typical Ridge Cap with Ply Underlay p⁶²

D-14 - SK1N Vented Ridge Cap with Ply Underlay p⁶²

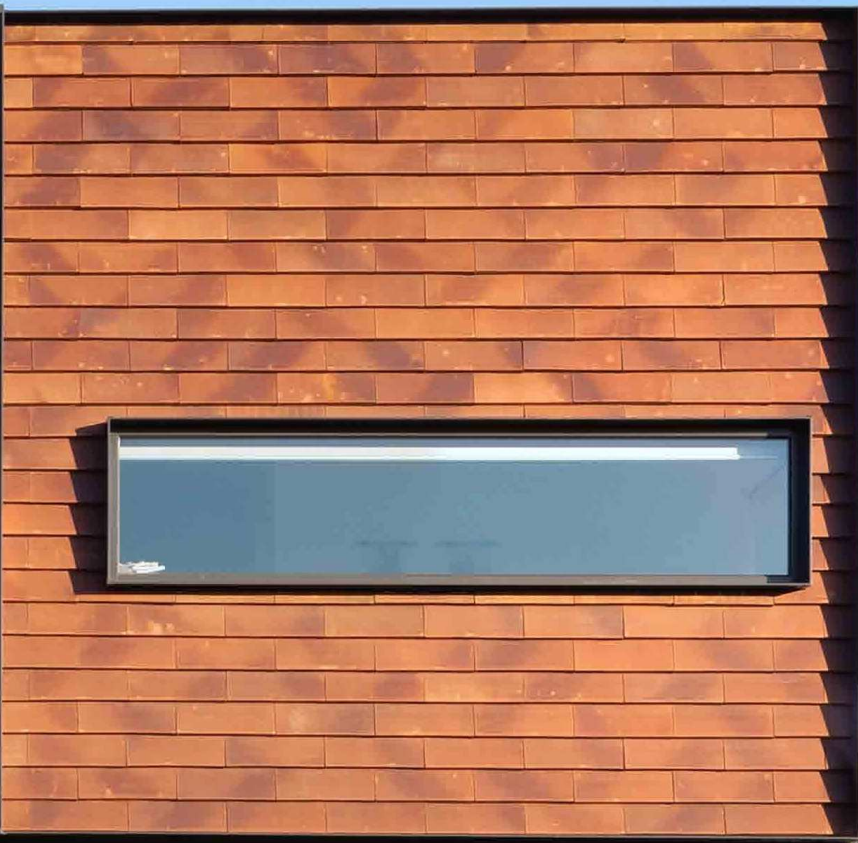
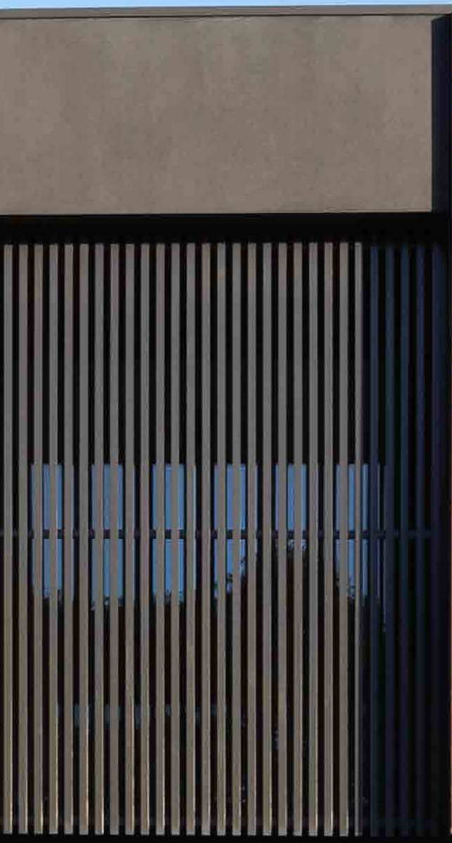

5.1 Design Details

Walling

D-01
General Walling
Front View of SK1N System

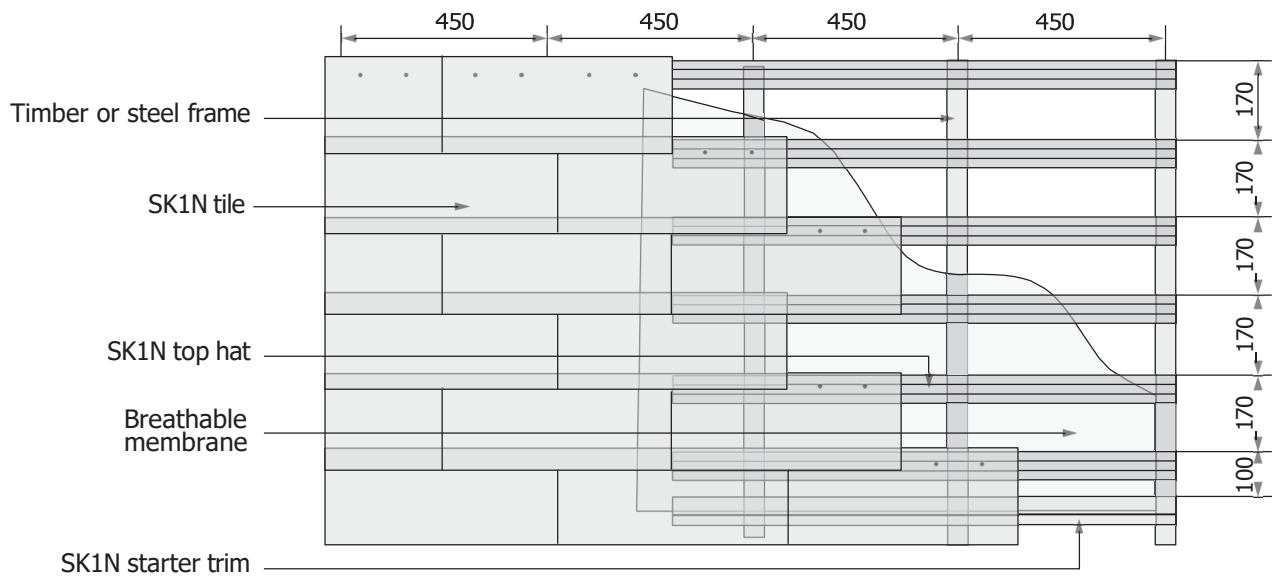

D-02
Plan View of SK1N System

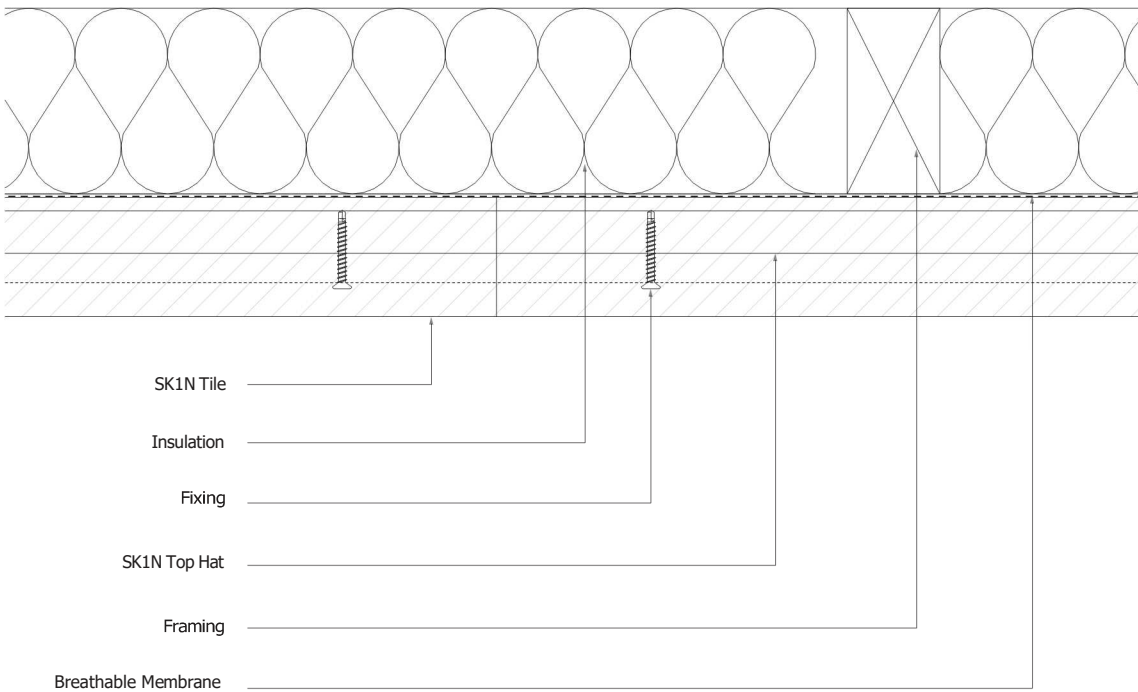

Design Details Walling

D-03A

Section View of L Shape on Timber Battens or SK1N Top Hats

L Profile with Timber Battens

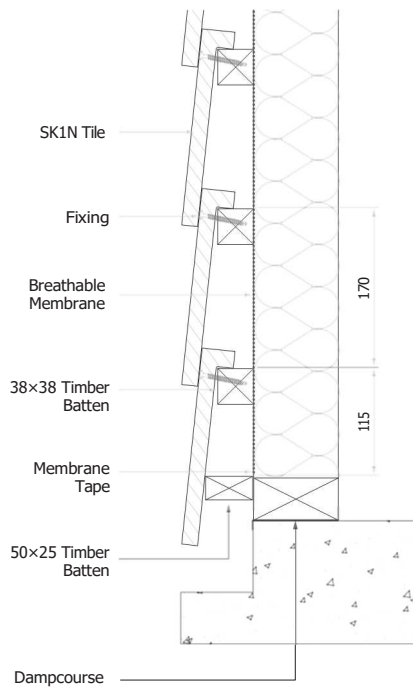

L Profile with SK1N Top Hats

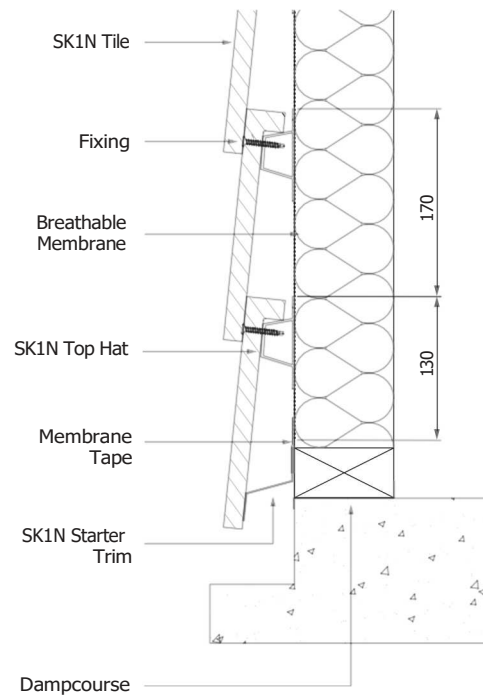

For minimum height above slab, see page 41

D-03B
Section View of U Shape on
Timber Battens or SK1N Top Hats

U Profile with Timber Battens

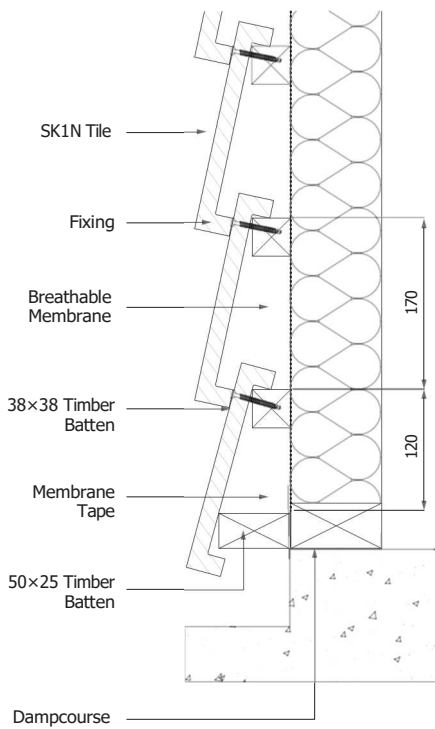

U Profile with SK1N Top Hats

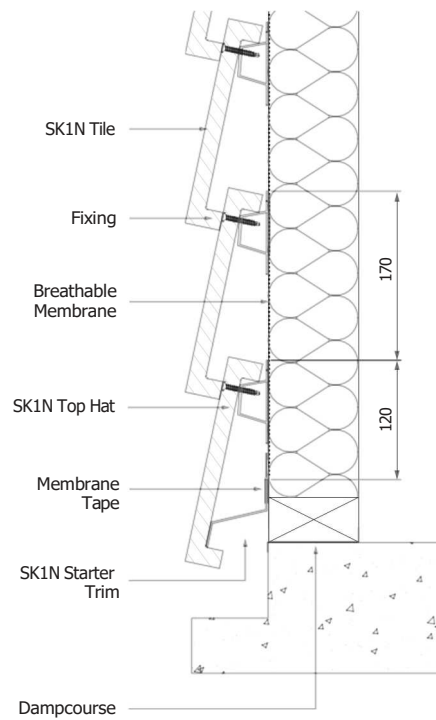

For minimum height above slab, see page 41

Design Details Walling

D-04 Cavity Options

Cavity Fix with SK1N Top Hats

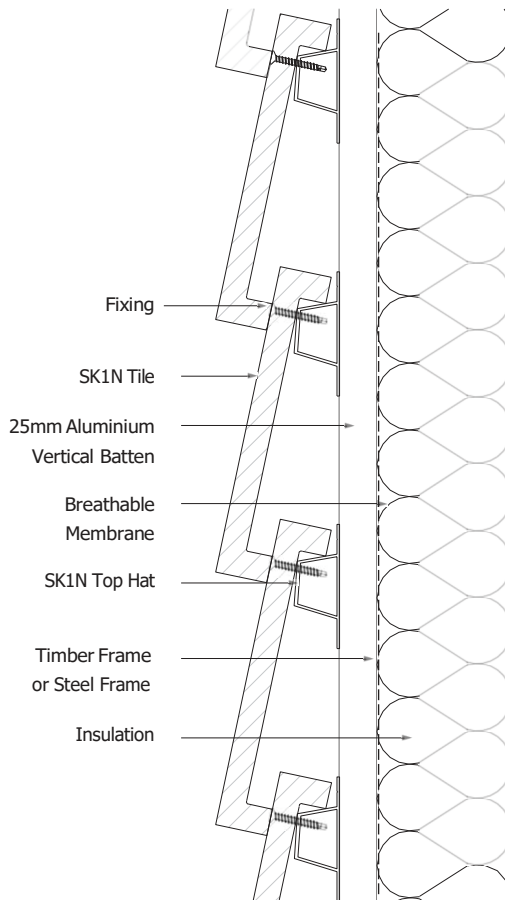

Cavity Fix with Timber Battens

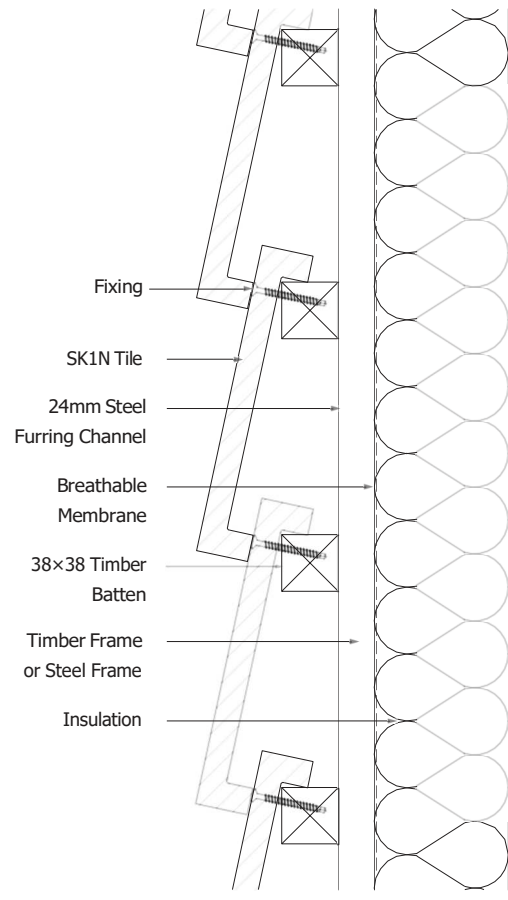

Design Details

Walling

D-05
Internal Corner

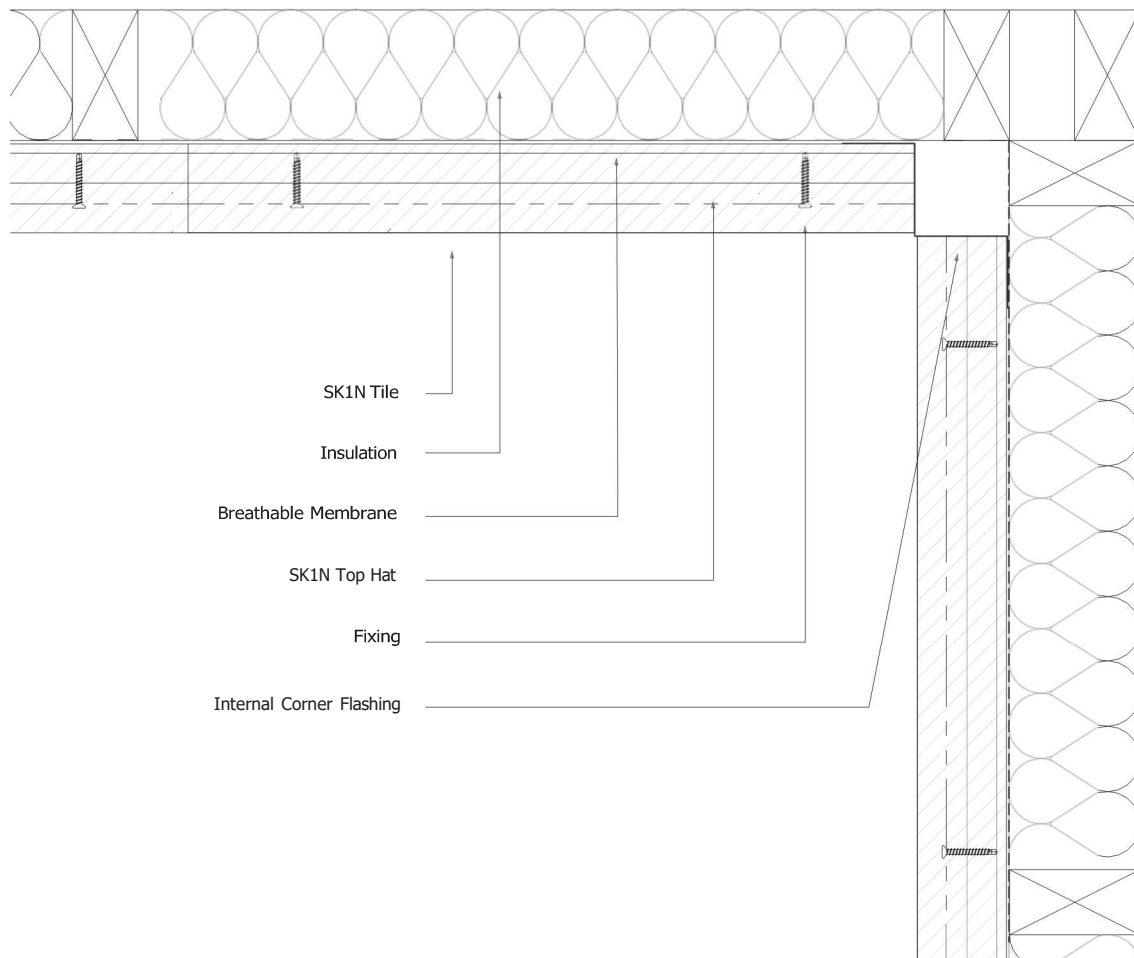

D-06

External Corner Options

External Corner with Accent Trim

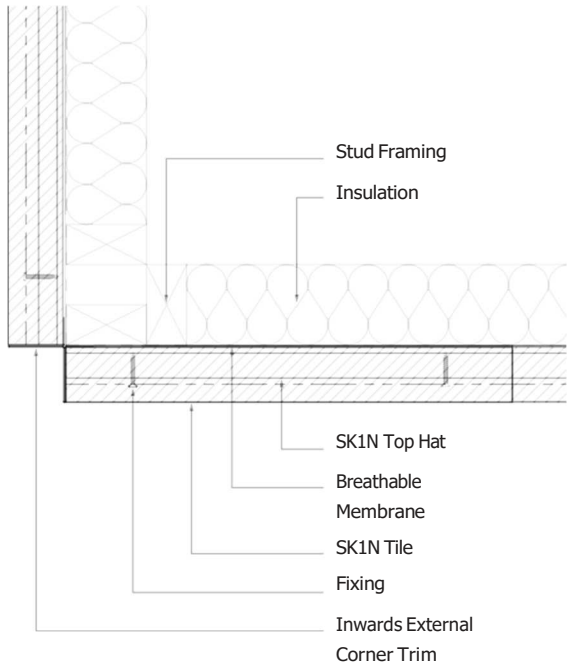

External Corner with Box Trim

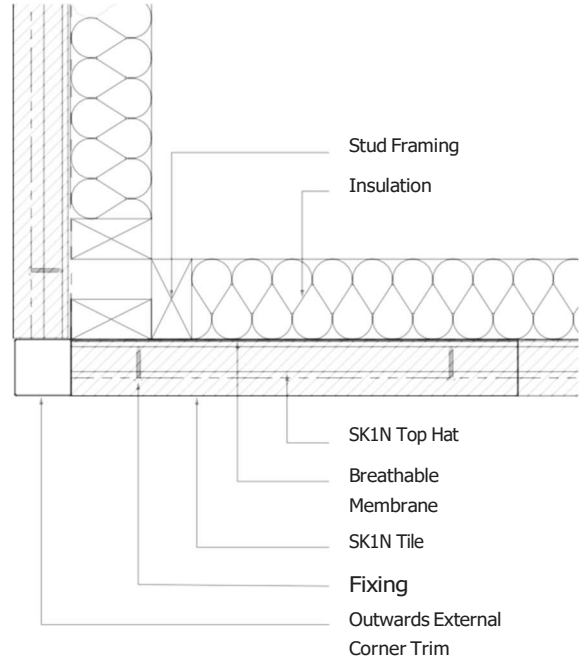

External Corner with Mitre

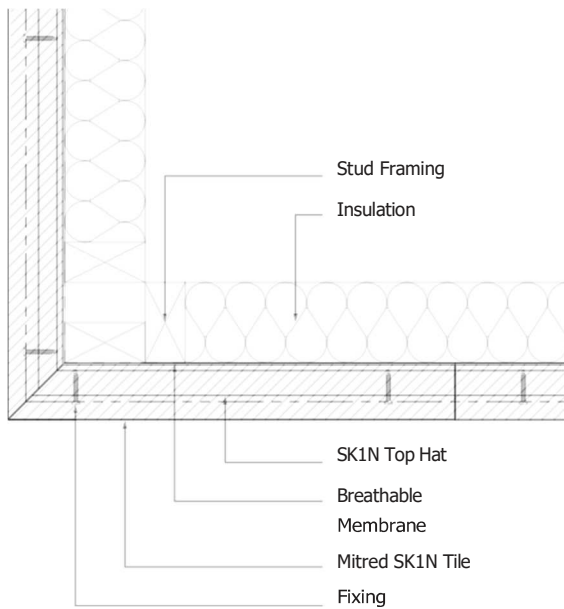

Mitred External Corner with Y Fin Trim

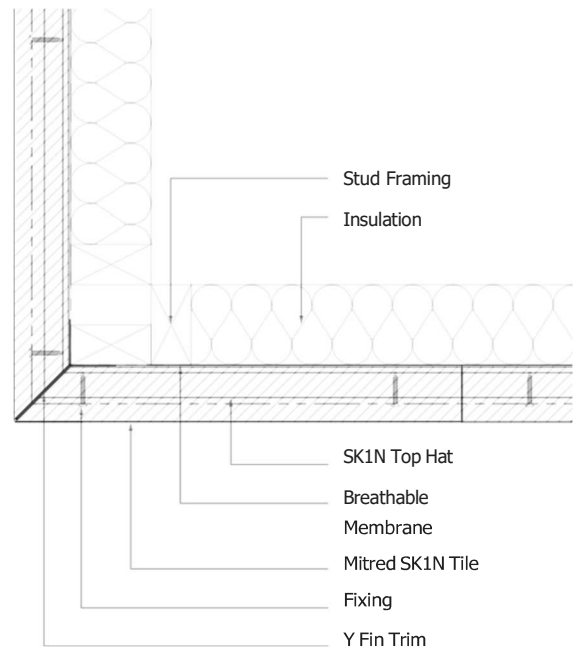

D-07

Cutting Guide for External Corner Tiles

L Shape External Corner Assembly

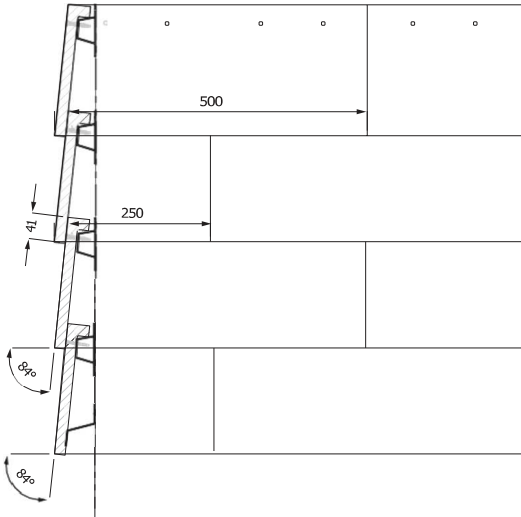

Corner Detail Cutting Guide for L Shape

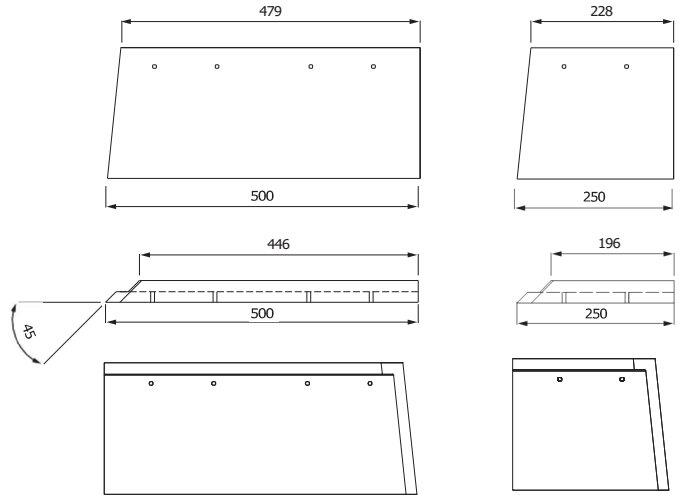

U Shape External Corner Assembly

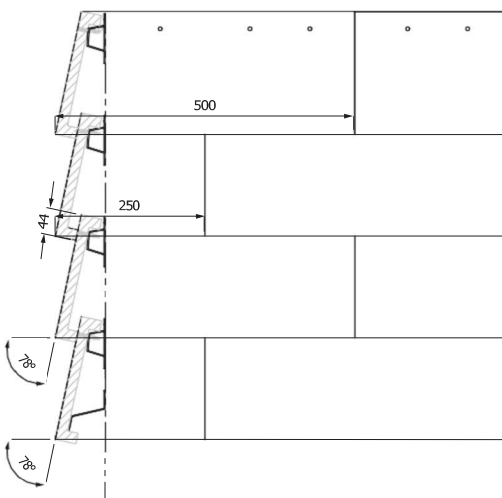

Corner Detail Cutting Guide for U Shape

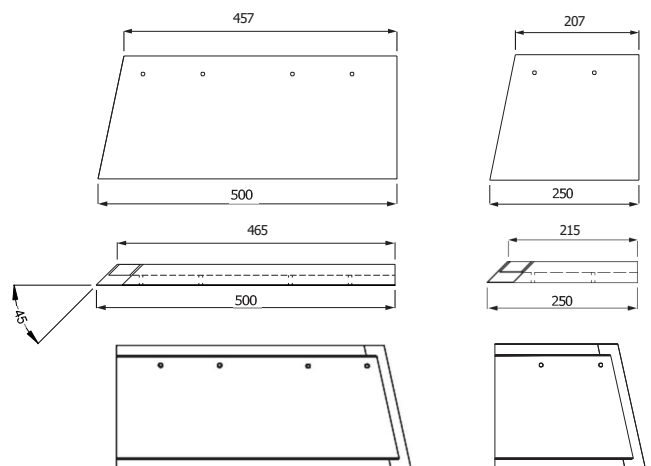

Design Details

D-08A
Window Sill

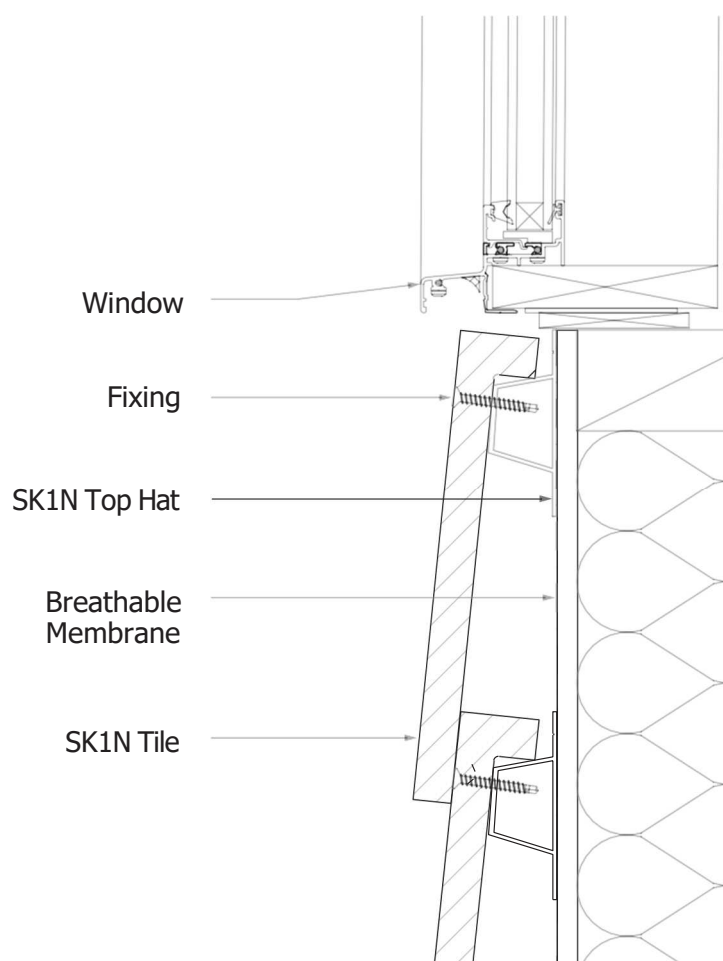

D-08B
Window Head

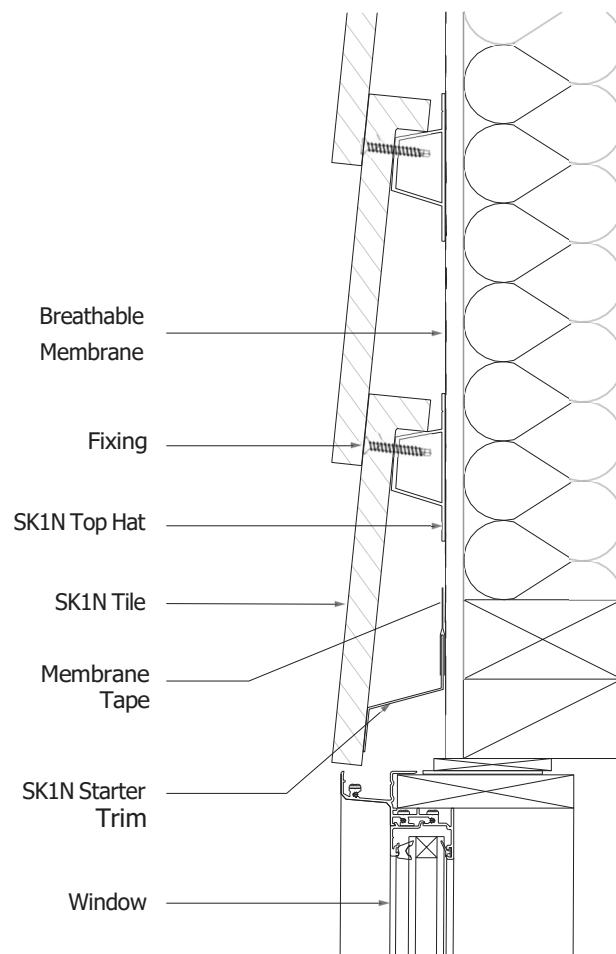

Design Details

D-09

Eave Junction

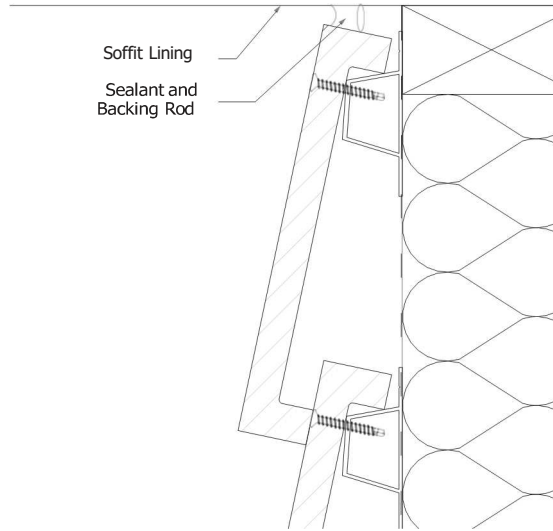

D-10

Roof with Box Gutter Detail

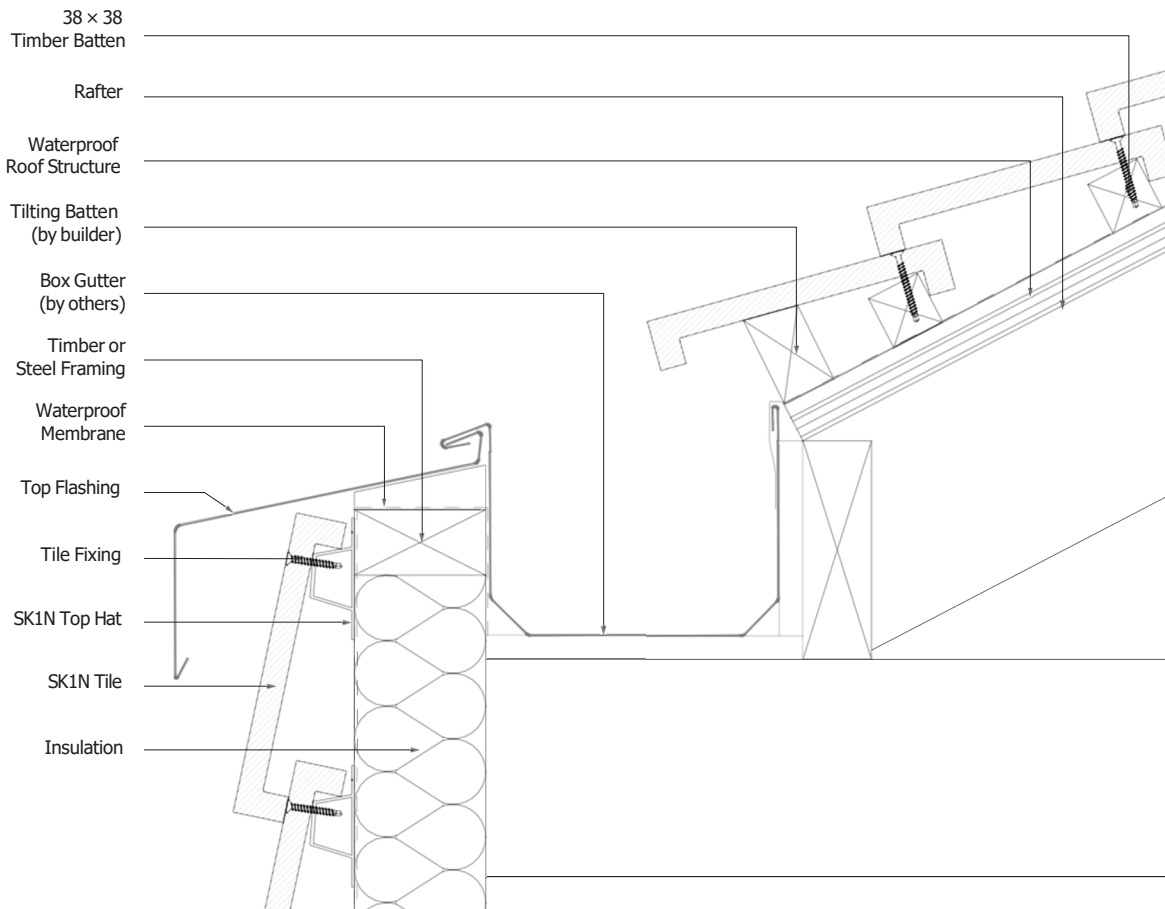

Design Details Roofing

D-11A

SK1N Roof with Ply Underlay - Section

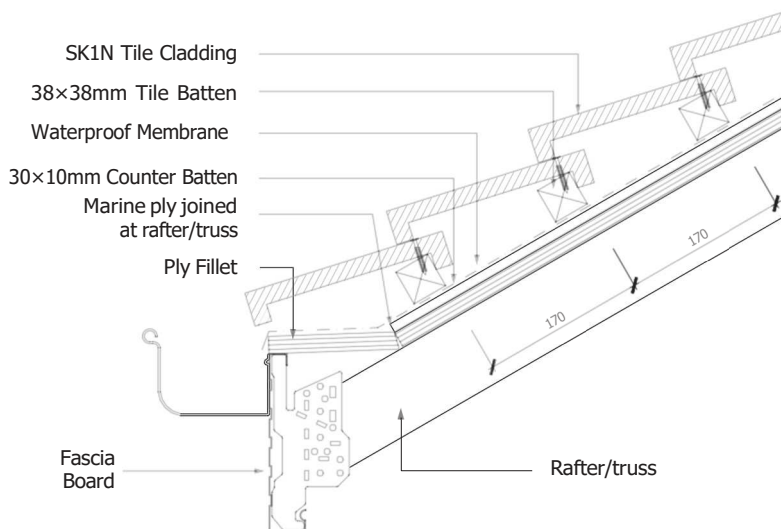
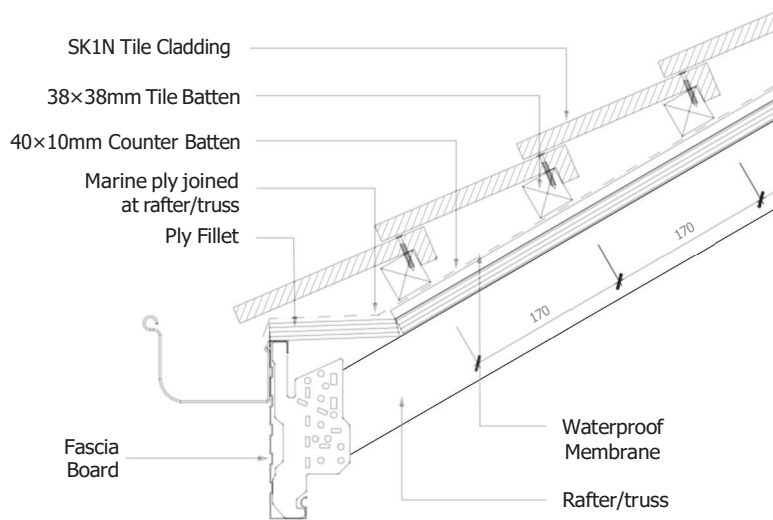

Design Details

Roofing

D-11B

SK1N Roof with Ply Underlay - Elevation

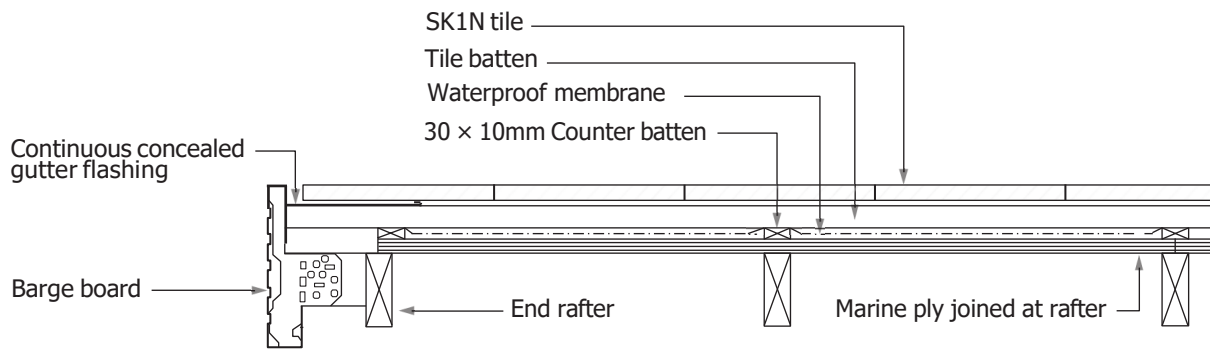

Note: Timber battens are interchangeable with SK1N top hats

Typical Ridge Cap with Ply Underlay

L Profile

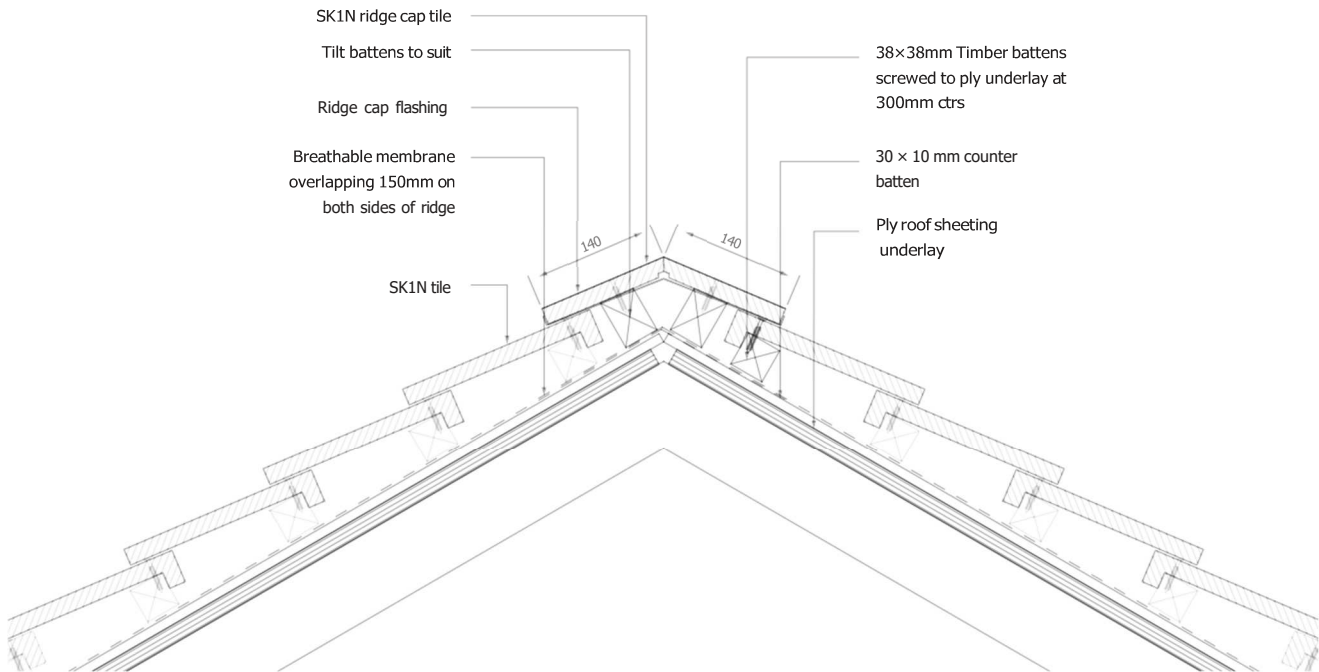

U Profile

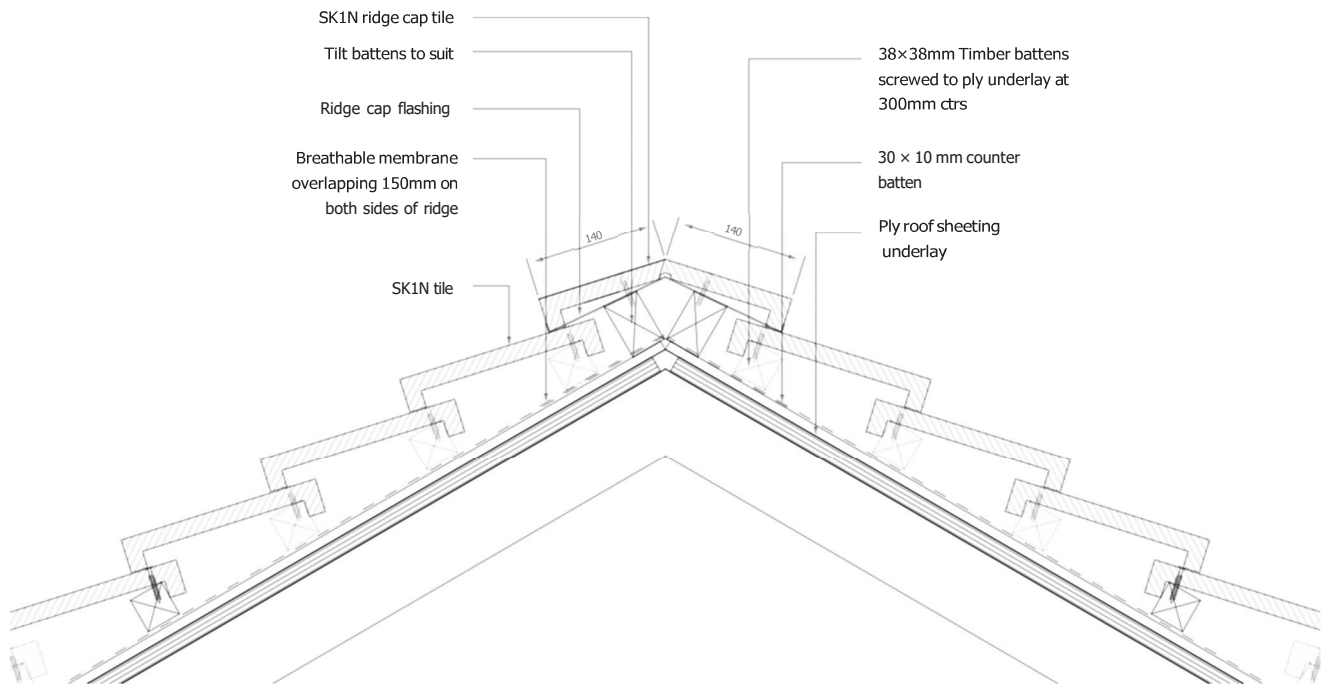

Design Details Roofing

D-13

SK1N Vented Ridge Cap with Ply Underlay

L Profile

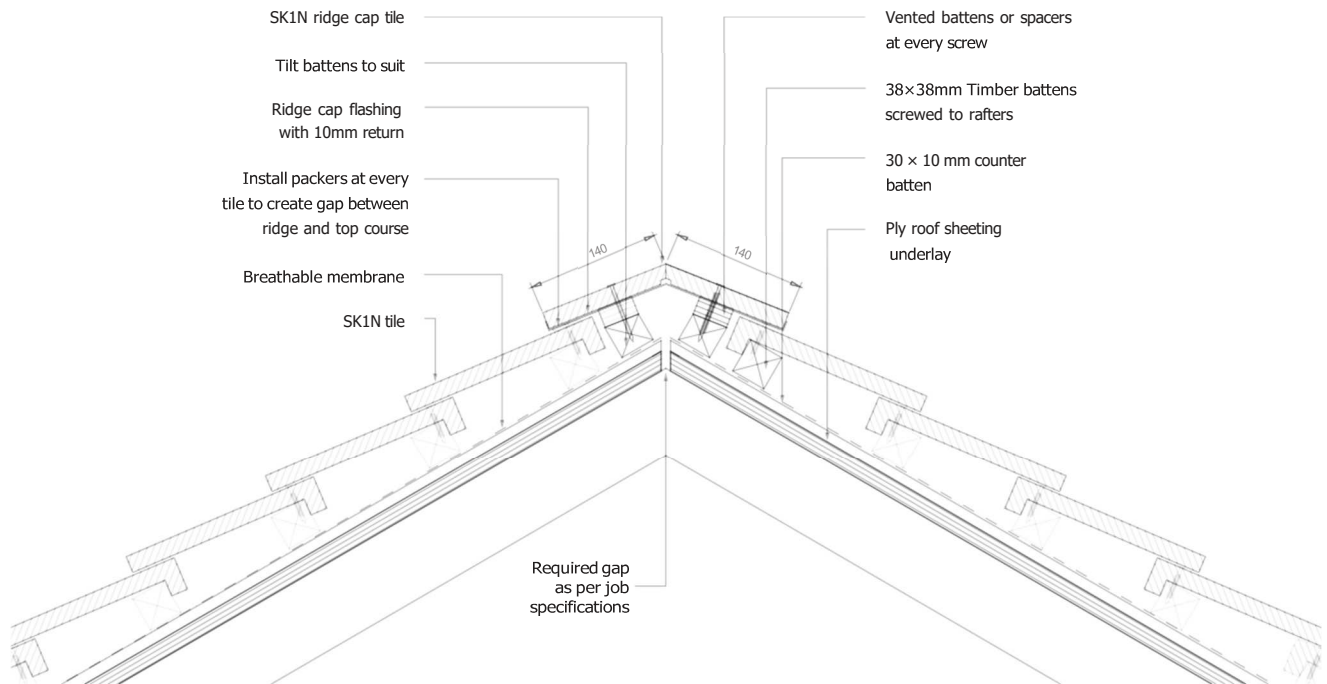

U Profile

